

# Thermowells and Bosses

TW, TS, TF, TJ and BS Series



## **FITOK Group**

### **FITOK GmbH (Headquarter)**

Spremlinger Landstr. 115, 63069 Offenbach, Germany  
Tel.: +49 69 8900 4498  
Fax: +49 69 8900 4495

### **FITOK INC.**

13000 Murphy Road, Suite 116, Stafford, TX 77477, USA  
Tel.: +1 281 888 0077  
Fax: +1 281 888 0033

### **FITOK INCORPORATED**

Yingtailong Industrial Park, Shenzhen, 518109, China  
Tel.: +86 755 2803 2500  
Fax: +86 755 2803 2619

info@fitokgroup.com  
www.fitokgroup.com

FI22040813

**FITOK**  
Valves and Fittings

www.fitokgroup.com

# Thermowells

## TW, TS, TF and TJ Series

### Features

- FITOK thermowells provide reliable heat-transmission performance under high temperature, high pressure, and corrosive conditions.
- Rugged mechanical construction ensures resistance to distortion under sharp temperature fluctuation conditions.
- Straight, stepped, and tapered shank designs are available.
- Standard instrument connection is 1/2 NPT, other connections are available on request.
- Materials include 316 SS, 304 SS, 321 SS, F91, F92, 316H SS, carbon steel, brass, titanium, alloy C-276 and alloy 400.

### Velocity Ratings

When selecting a thermowell, take maximum fluid velocity rating into consideration to avoid failure due to resonance vibration, as well as connection type, insertion length, and bore diameter.

Please refer to the table below for the maximum fluid velocities:

### Maximum Fluid Velocities (ft/sec)

Shank Style	Root Dia. in.	Material	Process Fluid	Immersion Length							
				2.5"	4.5"	7.5"	10.5"	13.5"	16.5"	19.5"	22.5"
Stepped	3/4	Brass	Liquid/Gas	59.3/207.0	39.8/89.1	23.9/32.3	16.4	9.9	6.6	4.8	3.6
		Carbon Steel	Liquid/Gas	106.0/290.0	71.2/123.0	42.7/44.9	22.8	13.8	9.3	6.7	4.9
		304 SS, 316 SS	Liquid/Gas	148.0/300.0	99.3/128.0	46.4	23.6	14.3	9.6	6.9	5.1
	7/8	Brass	Liquid/Gas	59.3/207.0	47.6/102.0	37.0/28.0	18.8	11.4	7.6	5.5	4.1
		Carbon Steel	Liquid/Gas	106.0/290.0	84.3/143.0	51.6/50.6	26.2	15.9	10.6	7.6	5.7
		304 SS, 316 SS	Liquid/Gas	148.0/300.0	117.0/148.0	53.5	27.2	16.5	11.0	7.9	5.9
Straight	Any	Brass	Liquid/Gas	145.0/290.0	80.0/150.0	48.0/54.1	27.6	16.7	11.1	8.0	6.0
		Carbon Steel	Liquid/Gas	260.0/326.0	144.0/192.0	69.5	35.4	20.5	14.3	10.3	7.7
		304 SS, 316 SS	Liquid/Gas	360.0/349.0	199.0	71.9	36.6	21.2	14.8	10.7	8.0
		Monel	Liquid/Gas	316.0/320.0	178.0/189.0	68.1	34.8	20.8	14.0	10.0	7.5
Tapered	Any	Carbon Steel	Liquid/Gas	270.0/410.0	150.0/249.0	90.3	45.6	27.8	18.5	13.2	9.8
		304 SS, 316 SS	Liquid/Gas	350.0/483.0	208.0/272.0	97.3	49.7	30.4	20.3	14.5	10.7
		Monel	Liquid/Gas	300.0/396.0	167.0/214.0	77.5	39.2	23.8	16.0	10.3	7.7

### TW series

Straight

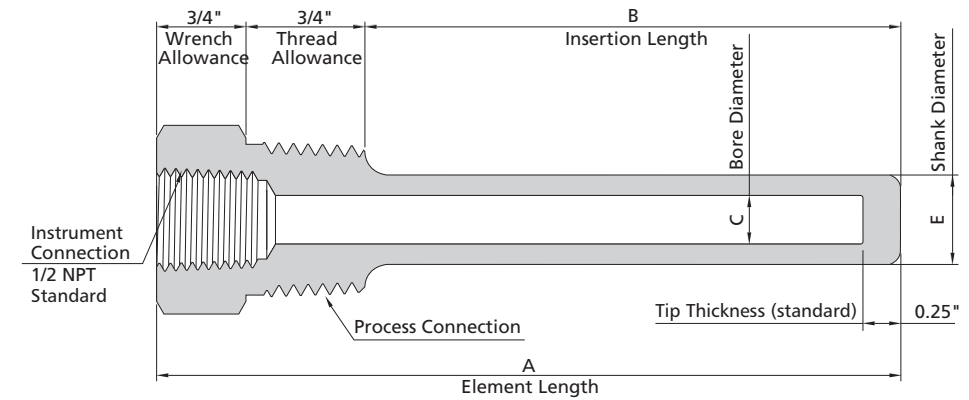

### Standard Sizes

Instrument Connection	Process Connection	Dimension, in. (mm)				
		C	E	B	A	
1/2 NPT Standard	3/4 NPT	0.413 (10.5)	0.750 (19.0)	4.5 (114.3)	6 (152.4)	
	1 NPT			7.5 (190.5)	9 (228.6)	
	3/4 NPT					
	3/4 NPT	1 NPT	0.656 (16.6)	1.060 (27.0)	2.5 (63.5)	4 (101.6)
					4.5 (114.3)	6 (152.4)
					7.5 (190.5)	9 (228.6)
					10.5 (266.7)	12 (304.8)
					13.5 (342.9)	15 (381.0)
					16.5 (419.1)	18 (457.2)
	1 NPT	3/4 NPT	0.385 (9.8)	0.750 (19.0)	22.5 (571.5)	24 (609.6)
					2.5 (63.5)	4 (101.6)
					4.5 (114.3)	6 (152.4)
7.5 (190.5)					9 (228.6)	
10.5 (266.7)					12 (304.8)	
13.5 (342.9)					15 (381.0)	
1 NPT	3/4 NPT	0.385 (9.8)	0.750 (19.0)	16.5 (419.1)	18 (457.2)	
				22.5 (571.5)	24 (609.6)	
				2.5 (63.5)	4 (101.6)	

Stepped

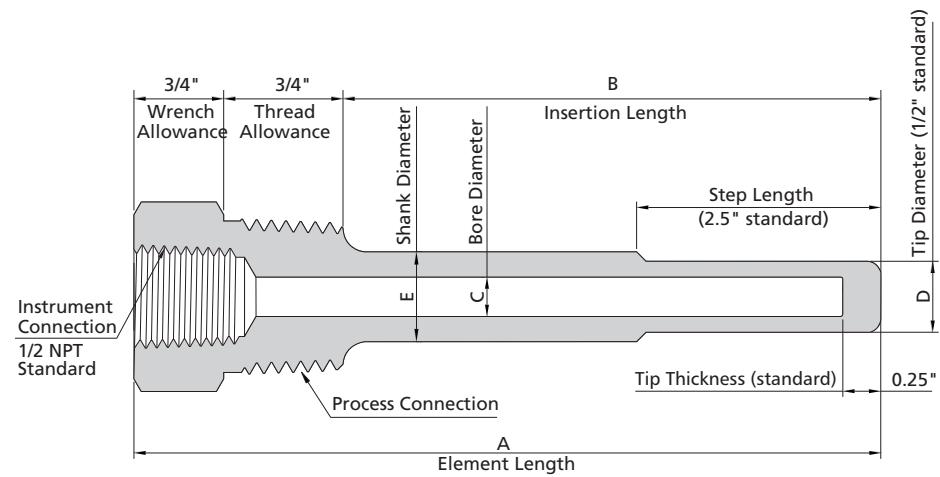

Standard Sizes

Instrument Connection	Process Connection	Dimension, in. (mm)			
		C	E	B	A
1/2 NPT Standard	1/2 NPT	0.260 (6.6)	0.625 (16.0)	2.5 (63.5)	4 (101.6)
				4.5 (114.3)	6 (152.4)
				7.5 (190.5)	9 (228.6)
				10.5 (266.7)	12 (304.8)
				13.5 (342.9)	15 (381.0)
				16.5 (419.1)	18 (457.2)
				22.5 (571.5)	24 (609.6)
				2.5 (63.5)	4 (101.6)
	3/4 NPT	0.260 (6.6)	0.750 (19.0)	4.5 (114.3)	6 (152.4)
				7.5 (190.5)	9 (228.6)
				10.5 (266.7)	12 (304.8)
				13.5 (342.9)	15 (381.0)
				16.5 (419.1)	18 (457.2)
				22.5 (571.5)	24 (609.6)
				2.5 (63.5)	4 (101.6)
				1 NPT	0.260 (6.6)
	7.5 (190.5)	9 (228.6)			
	10.5 (266.7)	12 (304.8)			
	13.5 (342.9)	15 (381.0)			
	16.5 (419.1)	18 (457.2)			
	22.5 (571.5)	24 (609.6)			
	2.5 (63.5)	4 (101.6)			
	4.5 (114.3)	6 (152.4)			

Tapered

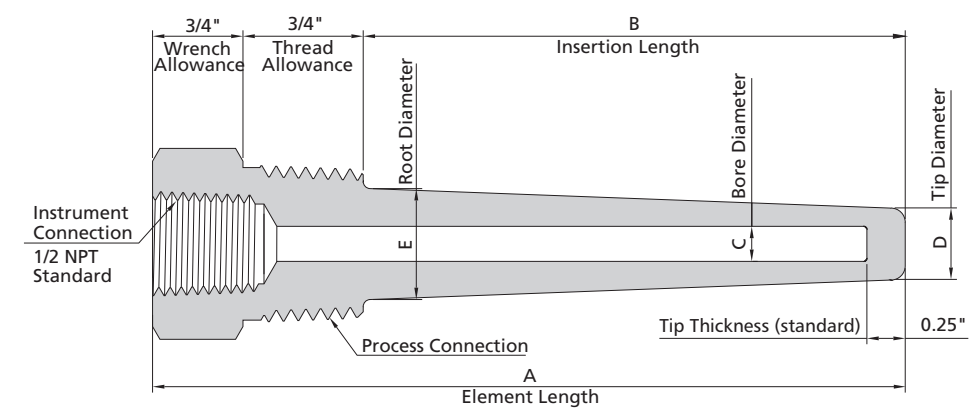

Standard Sizes

Instrument Connection	Process Connection	Dimension, in. (mm)				
		C	E	D	B	A
1/2 NPT Standard	3/4 NPT	0.260 (6.6)	0.875 (22.3)	0.625 (16.0)	2.5 (63.5)	4 (101.6)
					4.5 (114.3)	6 (152.4)
					7.5 (190.5)	9 (228.6)
					10.5 (266.7)	12 (304.8)
					13.5 (342.9)	15 (381.0)
					16.5 (419.1)	18 (457.2)
					22.5 (571.5)	24 (609.6)
					2.5 (63.5)	4 (101.6)
	1 NPT	0.260 (6.6)	1.060 (27.0)	0.625 (16.0)	4.5 (114.3)	6 (152.4)
					7.5 (190.5)	9 (228.6)
					10.5 (266.7)	12 (304.8)
					13.5 (342.9)	15 (381.0)
					16.5 (419.1)	18 (457.2)
					22.5 (571.5)	24 (609.6)
					2.5 (63.5)	4 (101.6)
					3/4 NPT	0.385 (9.8)
	7.5 (190.5)	9 (228.6)				
	10.5 (266.7)	12 (304.8)				
	13.5 (342.9)	15 (381.0)				
	16.5 (419.1)	18 (457.2)				
	22.5 (571.5)	24 (609.6)				
	2.5 (63.5)	4 (101.6)				
	1 NPT	0.385 (9.8)	1.060 (27.0)	0.750 (19.0)		
					7.5 (190.5)	9 (228.6)
10.5 (266.7)					12 (304.8)	
13.5 (342.9)					15 (381.0)	
16.5 (419.1)					18 (457.2)	
22.5 (571.5)					24 (609.6)	
2.5 (63.5)					4 (101.6)	
4.5 (114.3)					6 (152.4)	

TS series

Straight

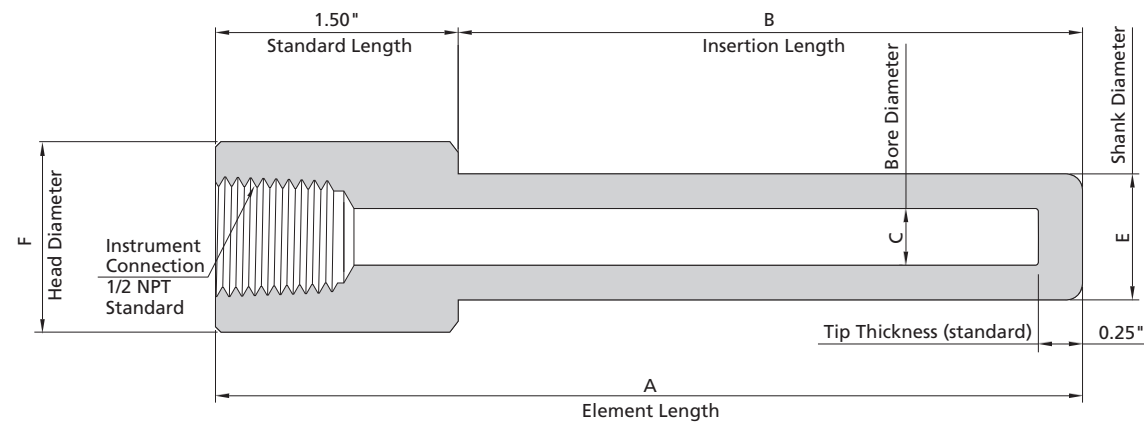

Standard Sizes

Instrument Connection	Dimension, in. (mm)				
	C	E	F	B	A
1/2 NPT Standard	0.260 (6.6)	0.750 (19.0)	1.060 (27.0)	2.5 (63.5)	4 (101.6)
				4.5 (114.3)	6 (152.4)
				7.5 (190.5)	9 (228.6)
				10.5 (266.7)	12 (304.8)
				13.5 (342.9)	15 (381.0)
				16.5 (419.1)	18 (457.2)
				22.5 (571.5)	24 (609.6)
	0.260 (6.6)	0.875 (22.3)	1.315 (33.5)	2.5 (63.5)	4 (101.6)
				4.5 (114.3)	6 (152.4)
				7.5 (190.5)	9 (228.6)
				10.5 (266.7)	12 (304.8)
				13.5 (342.9)	15 (381.0)
				16.5 (419.1)	18 (457.2)
				22.5 (571.5)	24 (609.6)

Stepped

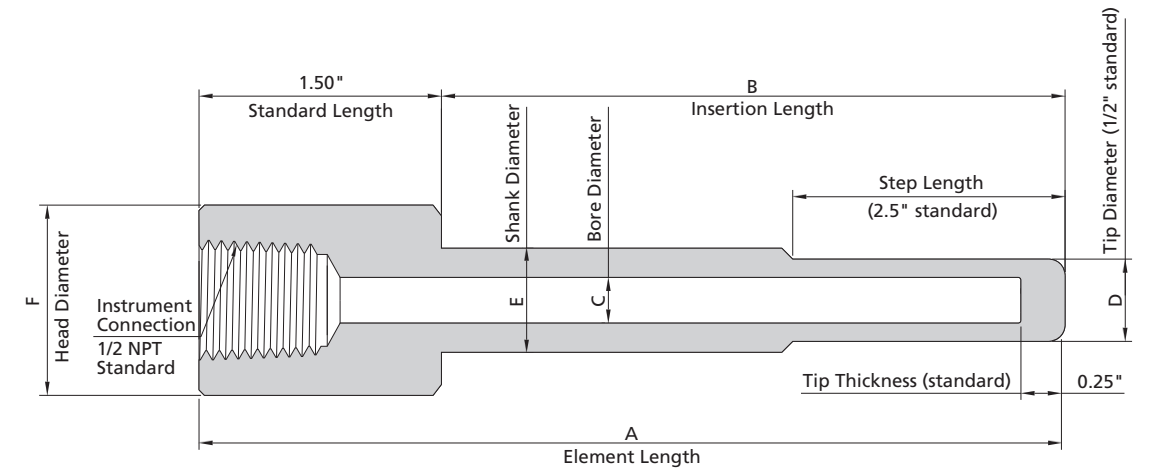

Standard Sizes

Instrument Connection	Dimension, in. (mm)				
	C	E	F	B	A
1/2 NPT Standard	0.260 (6.6)	0.750 (19.0)	1.060 (27.0)	2.5 (63.5)	4 (101.6)
				4.5 (114.3)	6 (152.4)
				7.5 (190.5)	9 (228.6)
				10.5 (266.7)	12 (304.8)
				13.5 (342.9)	15 (381.0)
				16.5 (419.1)	18 (457.2)
				22.5 (571.5)	24 (609.6)
	0.260 (6.6)	0.875 (22.3)	1.315 (33.5)	2.5 (63.5)	4 (101.6)
				4.5 (114.3)	6 (152.4)
				7.5 (190.5)	9 (228.6)
				10.5 (266.7)	12 (304.8)
				13.5 (342.9)	15 (381.0)
				16.5 (419.1)	18 (457.2)
				22.5 (571.5)	24 (609.6)

Tapered

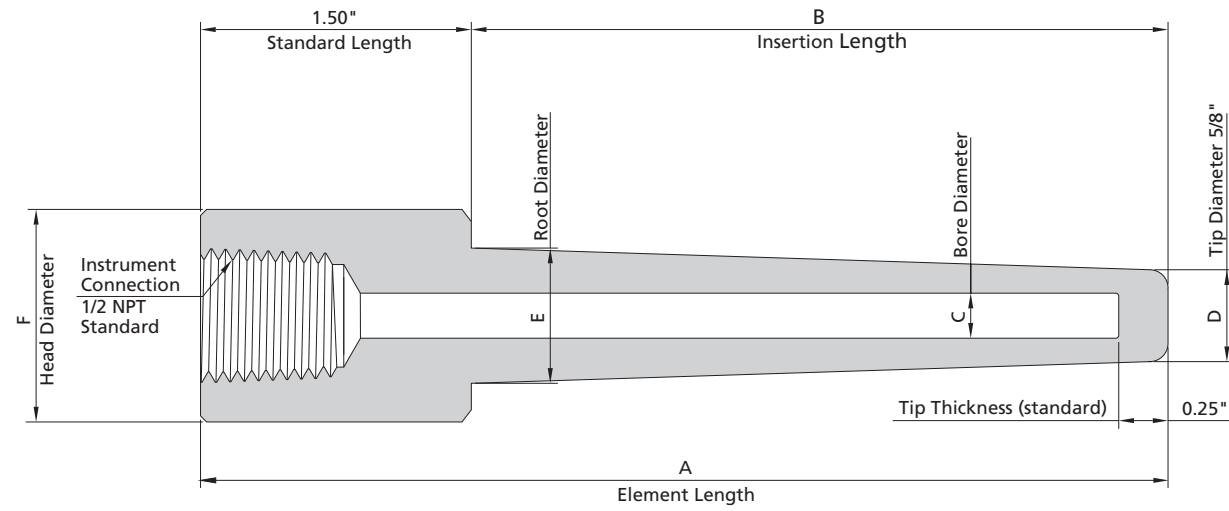

Standard Sizes

Instrument Connection	Dimension, in. (mm)				
	C	E	F	B	A
1/2 NPT Standard	0.260 (6.6)	0.750 (19.0)	1.060 (27.0)	2.5 (63.5)	4 (101.6)
				4.5 (114.3)	6 (152.4)
				7.5 (190.5)	9 (228.6)
				10.5 (266.7)	12 (304.8)
				13.5 (342.9)	15 (381.0)
				16.5 (419.1)	18 (457.2)
	0.260 (6.6)	1.060 (27.0)	1.315 (33.5)	2.5 (63.5)	4 (101.6)
				4.5 (114.3)	6 (152.4)
				7.5 (190.5)	9 (228.6)
				10.5 (266.7)	12 (304.8)
				13.5 (342.9)	15 (381.0)
				16.5 (419.1)	18 (457.2)
				22.5 (571.5)	24 (609.6)
				22.5 (571.5)	24 (609.6)

TF series

Straight

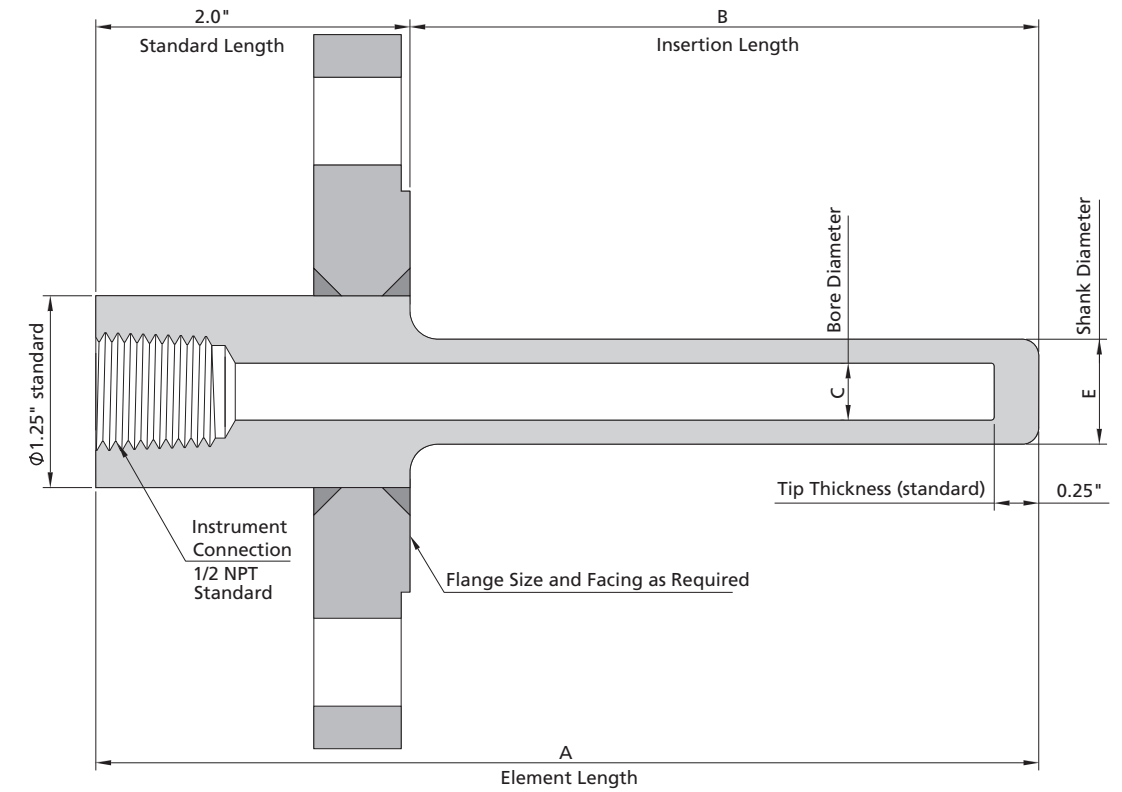

Standard Sizes

Instrument Connection	Process Connection	Dimension, in. (mm)			
		C	E	B	A
1/2 NPT Standard	1 Flange Raised Face ANSI Class 150	0.260 (6.6)	0.750 (19.0)	2 (50.8)	4 (101.6)
				4 (101.6)	6 (152.4)
				7 (177.8)	9 (228.6)
				10 (254.0)	12 (304.8)
				13 (330.2)	15 (381.0)
				16 (406.4)	18 (457.2)
	0.385 (9.8)	0.875 (22.3)	2 (50.8)	4 (101.6)	
			4 (101.6)	6 (152.4)	
			7 (177.8)	9 (228.6)	
			10 (254.0)	12 (304.8)	
			13 (330.2)	15 (381.0)	
			16 (406.4)	18 (457.2)	
			22 (558.8)	24 (609.6)	
			22 (558.8)	24 (609.6)	

Stepped

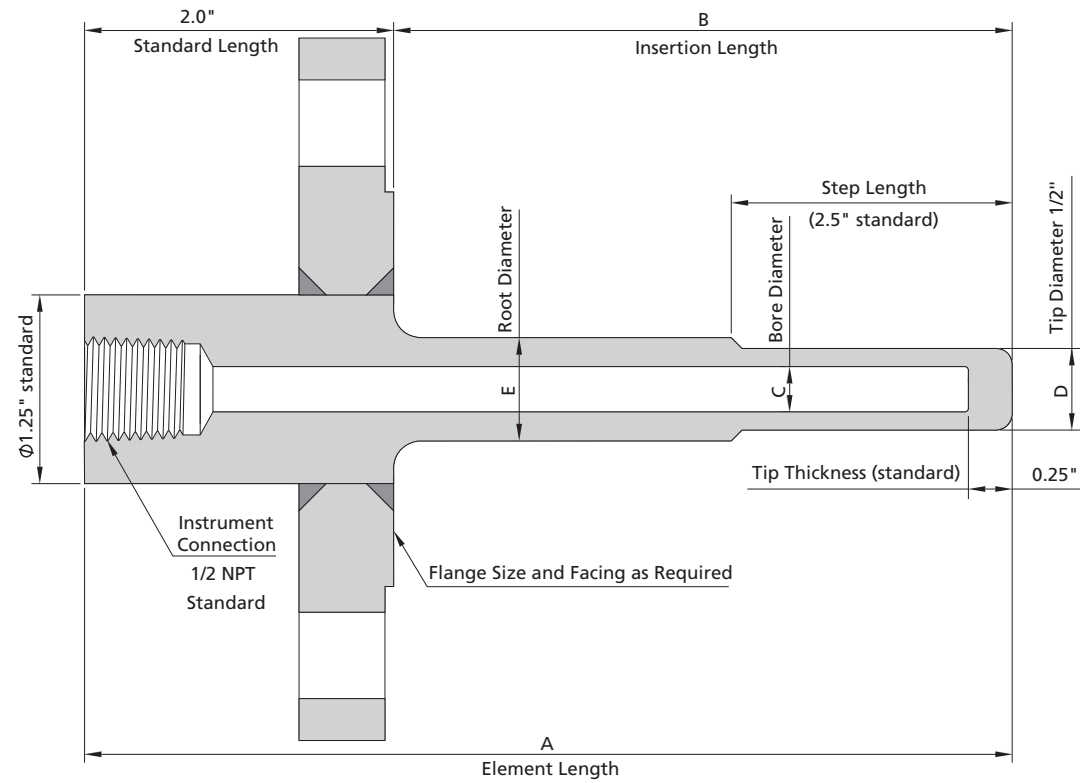

Tapered

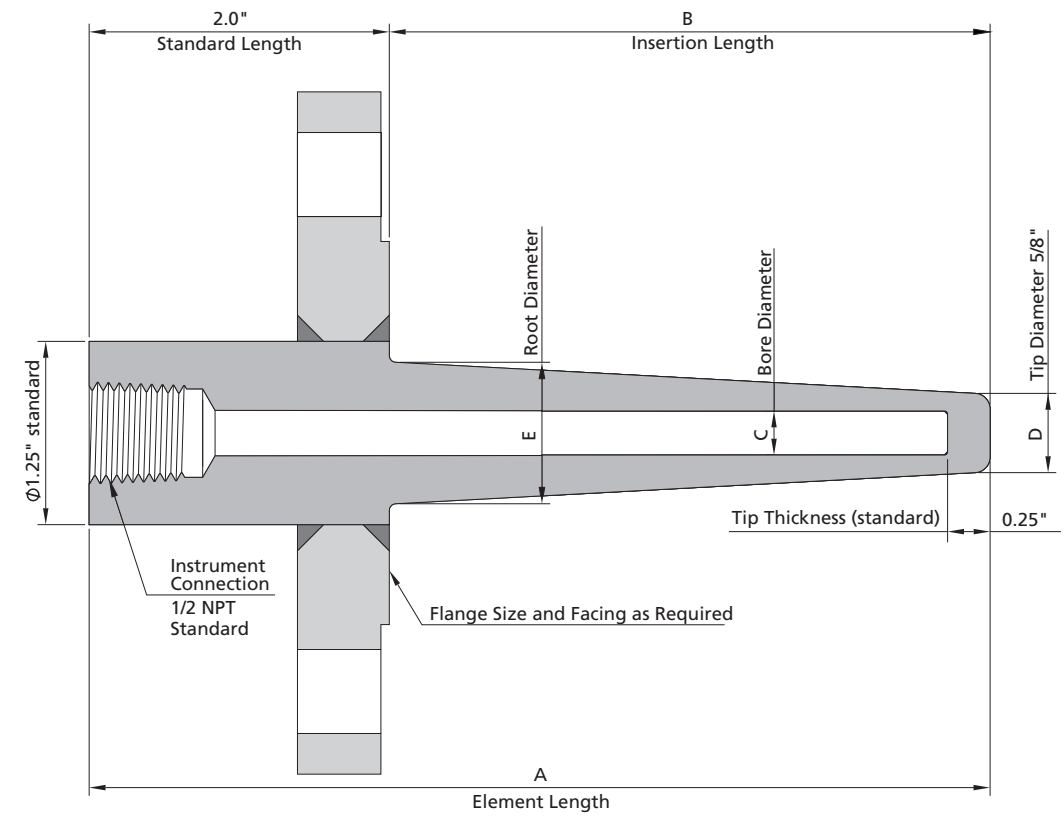

Standard Sizes

Instrument Connection	Process Connection	Dimension, in. (mm)			
		C	E	B	A
1/2 NPT Standard	1 Flange Raised Face ANSI Class 150	0.260 (6.6)	0.750 (19.0)	2 (50.8)	4 (101.6)
				4 (101.6)	6 (152.4)
				7 (177.8)	9 (228.6)
				10 (254.0)	12 (304.8)
				13 (330.2)	15 (381.0)
				16 (406.4)	18 (457.2)
	1 1/2 Flange Raised Face ANSI Class 150			22 (558.8)	24 (609.6)
				2 (50.8)	4 (101.6)
				4 (101.6)	6 (152.4)
				7 (177.8)	9 (228.6)
				10 (254.0)	12 (304.8)
				13 (330.2)	15 (381.0)
				16 (406.4)	18 (457.2)
				22 (558.8)	24 (609.6)

Standard Sizes

Instrument Connection	Process Connection	Dimension, in. (mm)			
		C	E	B	A
1/2 NPT Standard	1 Flange Raised Face ANSI Class 150	0.260 (6.6)	1.060 (27.0)	2 (50.8)	4 (101.6)
				4 (101.6)	6 (152.4)
				7 (177.8)	9 (228.6)
				10 (254.0)	12 (304.8)
				13 (330.2)	15 (381.0)
				16 (406.4)	18 (457.2)
	1 1/2 Flange Raised Face ANSI Class 150			22 (558.8)	24 (609.6)
				2 (50.8)	4 (101.6)
				4 (101.6)	6 (152.4)
				7 (177.8)	9 (228.6)
				10 (254.0)	12 (304.8)
				13 (330.2)	15 (381.0)
				16 (406.4)	18 (457.2)
				22 (558.8)	24 (609.6)

TJ series

Tapered

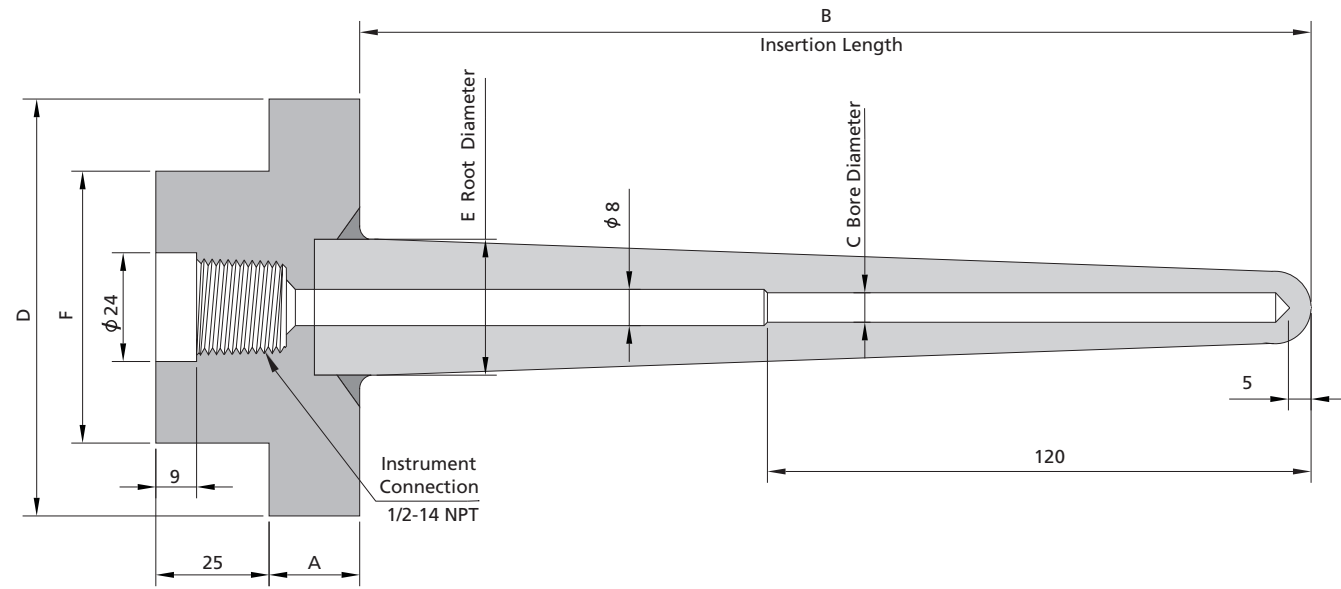

Standard Sizes

Instrument Connection	Process Connection	Dimension, mm						Application Liquid flow rate is less than 8m/s; Gas flow rate is less than 40m/s
		C	E	B	A	D	F	
1/2 NPT Normative	NPS 1 1/2 Flange Raised Face ANSI Class 300	6.5	30	215	15	73	48	Only apply to installation of pipeline
				240				
				290				
				340				
				390				
	NPS 2 Flange Raised Face ANSI Class 300	Base on Design	20	92	60	60	Only apply to installation of equipment and vessel	
								160
								215
								240
								290

Part Number Description

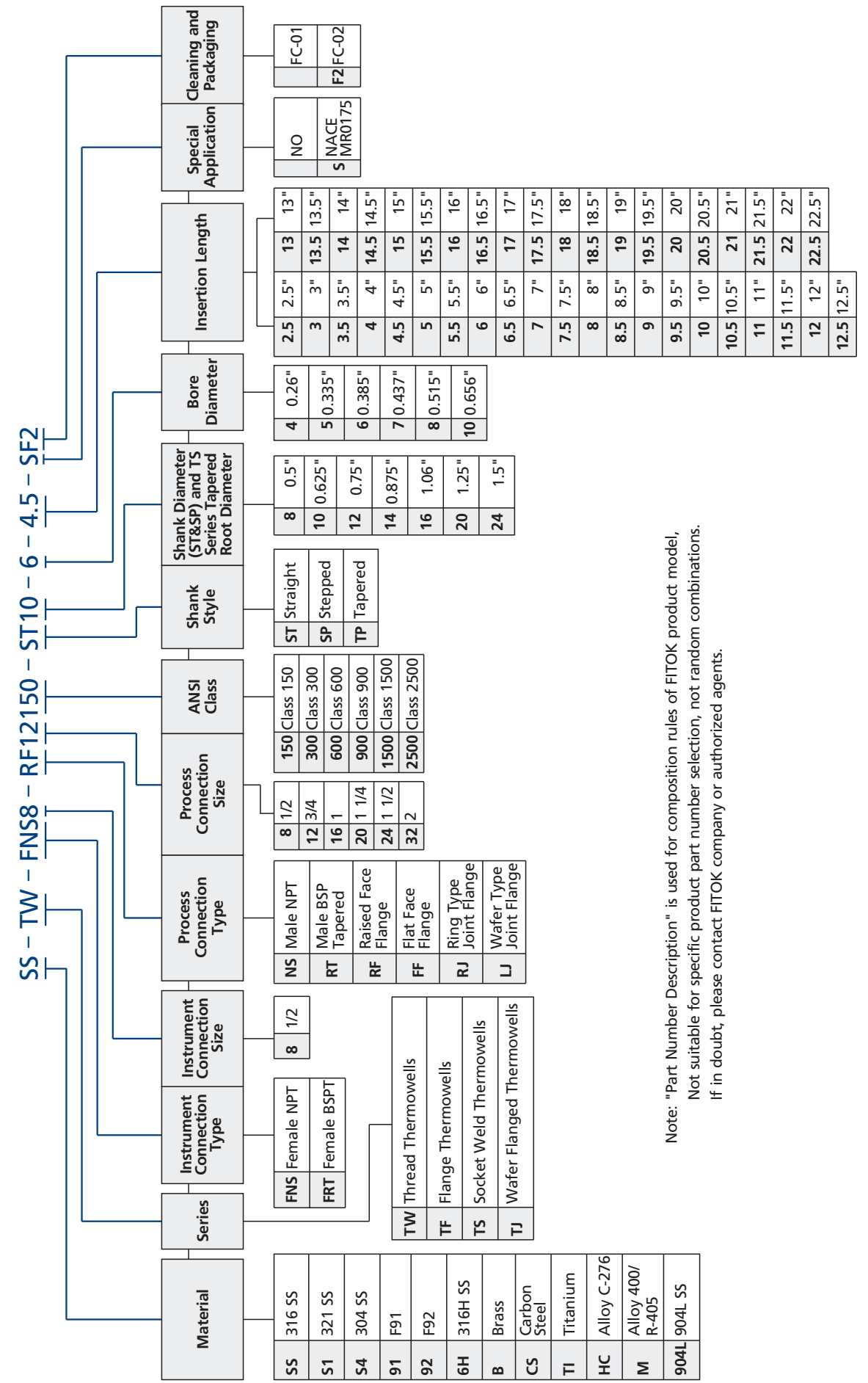

Note: "Part Number Description" is used for composition rules of FITOK product model, Not suitable for specific product part number selection, not random combinations. If in doubt, please contact FITOK company or authorized agents.

# Bosses

## BS Series

### Features

- Maximum working pressure: 1500 psig (104 bar)
- Solid bar stock boss
- Variety of end connections

### Dimensions

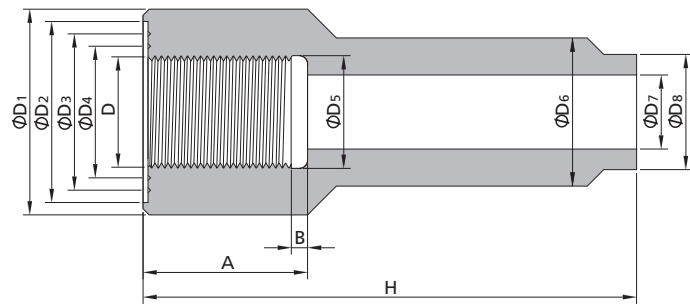

End Connection	Dimensions (mm)									Basic Ordering Number			
	D	ØD1	ØD2	ØD3	ØD4	ØD5	ØD6	ØD7	ØD8		A	B	H
M12 x 1.5		32	28	23	17	12.3	18	7	12	27	3	60	-BS-FMS12-7-27-60
												120	-BS-FMS12-7-27-120
M16 x 1.5		36	32	27	21	16.3	18	9	14	27	3	60	-BS-FMS16-9-27-60
												120	-BS-FMS16-9-27-120
M27 x 2.0		47	43	38	32	27.4	28	17	22	40	4	60	-BS-FMS27-17-40-60
												120	-BS-FMS27-17-40-120
M33 x 2.0		55	51	44	38	33.4	36	24	30	40	5	60	-BS-FMS33-24-40-60
												120	-BS-FMS33-24-40-120
1/2 Female BSPP		39	35	31	25	21.5	27	16	21	35	4	60	-BS-FRP8-16-35-60
												120	-BS-FRP8-16-35-120
3/4 Female BSPP		47	43	38	32	27.0	31	20	25	40	4	60	-BS-FRP12-20-40-60
												120	-BS-FRP12-20-40-120
1 Female BSPP		55	51	44	38	34.0	41	30	35	45	6	60	-BS-FRP16-30-45-60
												120	-BS-FRP16-30-45-120
M27 x 2.0		47	43			27.4	28	14	22	20	4	(80)	-BS-FMS27-14-20-80
												(140)	-BS-FMS27-14-20-140

- The boss with H in brackets shall be used for the thermometer with movable male thread (such as bimetal therm).
- When the boss is used for bimetal therm, the sealing slot at D3 and D4 shall not be processed.
- The boss of M27 x 2 shall be used for TIC or RTD when a=40, used for bimetal therm when a=20.
- The boss with H=120 or 140 shall be used for thermo-insulation objects.
- Dimensions are for reference only and are subject to change.
- Sizes and types listed are standard. Other sizes and types are available on request.
- Materials same as TW series, add the material designator as a prefix to the basic ordering number to get the complete ordering number.

### Part Number Description

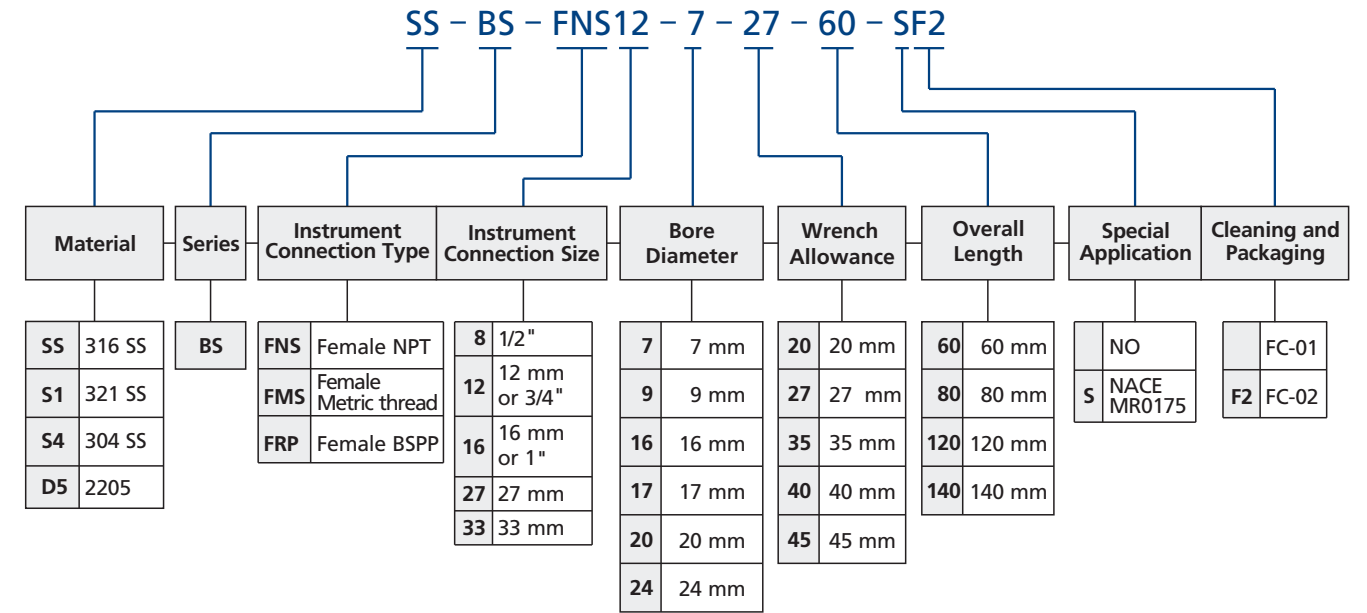

Note: "Part Number Description" is used for composition rules of FITOK product model, Not suitable for specific product part number selection, not random combinations. If in doubt, please contact FITOK company or authorized agents.